



GenSet

MGF 16 Y

Max Power 16 kVA



Engine Yanmar 3TNV88

Type	Diesel, 4 Stroke
Cooling system	Water cooled
Cylinders	3
Displacement (c.c. - cu.in)	1642 - 100
Engine output (hp)	18,4
RPM	1500
Injection system	Direct
Governor	Mechanical
Lubrication system	Forced
Oil sump capacity (L - gal)	6,7 - 1,8
Stop system	Solenoid
Fuel tank capacity (L - gal)	40 - 10,5
Autonomy 3/4 load (h)	16
Starter battery (Ah-V)	80 -12
Battery charger (Ah-V)	15 -12
Starter motor (kW-V)	1,4 / 12

Soundproof cabin

- With frame and openable hoods made of steel panels and epoxidic paint.

Engine

- Easy access in case of maintenance to the feeding system, lubrication system and air filter.
- Safety stop in case of low oil pressure.
- Safety stop in case of high water temperature.
- Oil and fuel filters are easily accessible and easily replaceable.
- Water cooled engine with radiator.

Control panel

- The **GenSet** control panel for manual starting and stopping has been designed and built to combine all the control instruments and warning lights and protections both for the engine and the generator.
- Control panel is made of painted steel plate and include the following main equipment:
 - Voltmeter • 4-pole circuit breaker and earth fault device • 3-pole magnetothermal switch 16A • 1-pole magnetothermal switch • Electronic device for automatic shutdown of the engine in case of HWT and LOP • Emergency stop pushbutton • Ignition key • Warning light for high cooling water temperature and low oil pressure • Hourmeter
 - Socket 32A 400V 3P+N+G • Socket 16A 400V 3P+G
 - N°2 Socket 2P+G 230V 16A

Generator

- Synchronous, 4 poles, self-excited
- Rotor and stator epoxidic resin coated against environmental agents.
- Rotor dynamically balanced.
- Insulation class H.

Generator

Type	Synchronous, 4 poles, selfexcited
Regulation	Compound
Voltage (V)	400 / 230
Frequency (Hz)	50
3-Phase data	400 V
Max. output	16 kVA
Cont.output	15 kVA
Power factor (cos ϕ)	0,8
Single-Phase data	230 V
Max. output	11 kVA
Power factor (cos ϕ)	1
Insulation class	H
Voltage stability	±10%
Frequency stability	±5%

STANDARD version

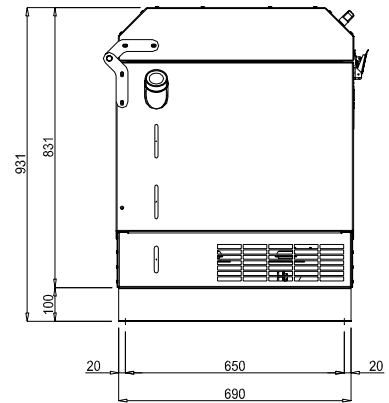
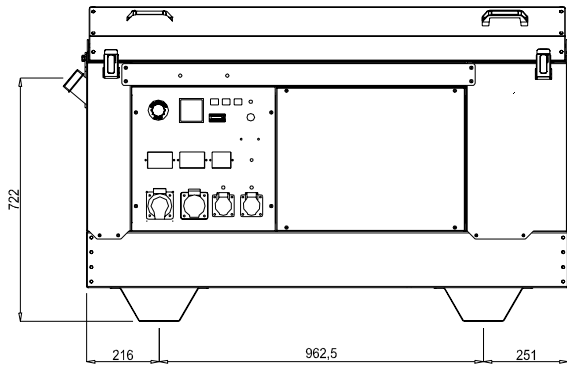

FIXED TOW version

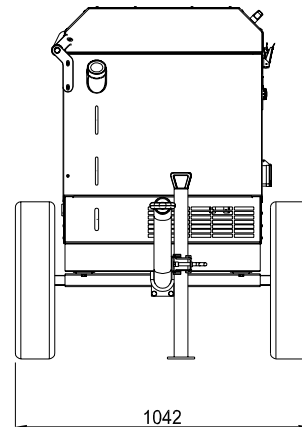
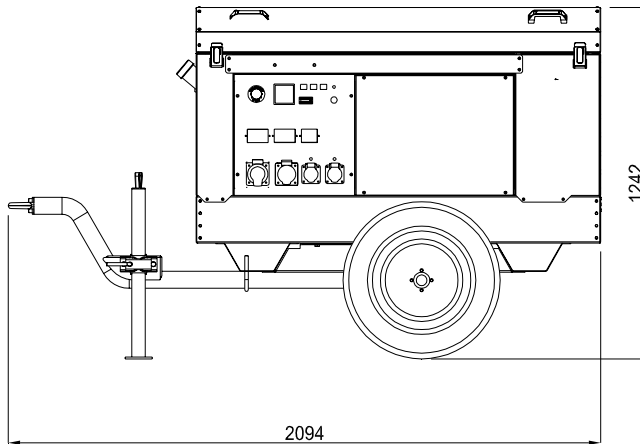

	MGF 16 BA	MGF 16 TF	
Lenght	1429,5 - 56,2	2094 - 82,5	mm - in
Width	690 - 27	1042 - 41	mm - in
Heigh	931 - 36,5	1242 - 49	mm - in
Weight	470 - 1036	500 - 1102	kg - lbs
Noise power level 96 LwA			

	MGF 16 BA	MGF 16 TF	
Lenght	1429,5 - 56,2	2094 - 82,5	mm - in
Width	690 - 27	1042 - 41	mm - in
Heigh	931 - 36,5	1242 - 49	mm - in
Weight	470 - 1036	500 - 1102	kg - lbs

Noise power level 96 LwA

OPTIONALS:

SITE TOW VERSION

*This drawing is only a reference and is not indicatly for the installation. For more information, you may contact your local dealer or **GenSet** generators S.p.A.*

***GenSet** generators S.p.A. reserves the right to change the design or specifications without notice and without any obligations or liability whatsoever. For more information, you may contact your local **GenSet** dealer.*

Dealer:



GEN SET S.P.A. - 27030 VILLANOVA D'ARDENGI (PV) - ITALY - VIA STAZIONE, 5
TEL.: (+39)0382-5091 • FAX: (+39)0382-509-244
• EMAIL: GENSET@GENSET.IT